

## General Purpose Aluminum Connection Head Code 2

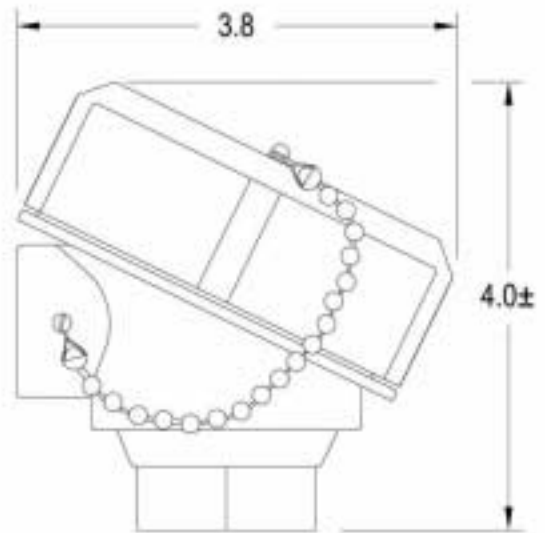

- Meets NEMA 4 & 4X requirements. Corrosion resistant coating is standard.
- Standard style instrument connection head suitable for temperature sensor assemblies.
- Connection head supplied with terminal block unless a Weed Instrument Sensor Mate<sup>®</sup> temperature transmitter is ordered.



Code	Description
2	<b>General Purpose Aluminum</b>
Code	General Extension Style and Material
A	None. For sensors with threaded instrument connections (i.e. model 305); or when ordered as a stand alone.
F	Nipple extension - Series 300 stainless steel (F=00 for close nipple).
G	Nipple/union Series 300 stainless steel 3" minimum.
H	Nipple/union/nipple Series 300 stainless steel 3" minimum.
J	Union/nipple - Series 300 stainless steel 3" minimum.
Code	Extension Length ("B" Dimension)
00	0" (close nipple)
10	1" (nipple extension only)
20	2" (nipple extension only)
30	3" (minimum with union)
40	4"
50	5"
60	6"
Other	Specify length
Code	Head Connections (Instruction x Conduit)
A	1/2" NPT x 1/2" NPT
D	1/2" NPT x 3/4" NPT - <b>Industry Standard</b>
Code	Gasket Type
1	Weatherproof - 200°F maximum - <b>Industry Standard</b>

