

- ▶ **40 Years Qualified Life**
IEEE-323 & IEEE-344
- ▶ **General Purpose RTD**
- ▶ **Spring Loaded for**
Thermowell Mounting
- ▶ **High Accuracy, Low**
Drift
- ▶ **For use in New Plant**
Construction or
Replacement Parts
- ▶ **Direct Replacement for**
Rosemount Model
104ACF



Shown with Thermowell and Adaptor

The Model N9356 Rigid RTD is designed for general purpose temperature monitoring in CANDU design power plants. The design incorporates modern materials which result in a high accuracy and low drift. Whether being used in new plant construction or replacement parts, the Weed design is unmatched in engineering and application flexibility.

The rigid RTD utilizes a multi-pin connector and a spring loaded design for maximum ease of use when installing or removing the sensor. The design incorporates standard RTD lengths for use with various length RTD-to-

Thermowell adapters, in order to minimize the number of spare parts that have to be kept in stores. RTDs can be supplied in the standard lengths with the adapter fittings or can be supplied in custom lengths.

RTDs are supplied in accordance with Weed Instrument's Quality Assurance Program which is ISO-9001 registered. The Program is also in compliance with CSA Z299.1, ASME NQA-1 & 10CFR50 Appendix B.

The Weed rigid RTD has an upgraded design that uses modern, but proven materials. The sheath material is stainless steel, while the insulation material is

MgO, which compacts better than Al_2O_3 since it has a smaller grain size. This means that an MgO filled cable has greater stability. The internal lead wires are Constantan, as opposed to nickel clad silver wire, which needs great care in manufacturing since a change in resistance can occur due to bending. Nickel clad silver also leads to a long term problem with silver migration in some applications. The Constantan eliminates both the silver migration and the varying resistance problems. This combination of materials has been successfully used in nuclear power plants.

Performance Specifications

Item	Specification
Resistance	100 ± 0.1ohm at 0 °C or 200 ± 0.2 ohm at 0 °C
Accuracy	Standard sensor accuracy is ± 0.5 °C. Tighter accuracies are available upon request. Each RTD is supplied with a calibration table for the applicable range and customer-specified interval. Sensors are repeatable to within ± 0.1 °C
Temperature Range	0 °C to 320 °C
Insulation Resistance	At room temperature and with dry external surfaces, the insulation resistance between each pin and the RTD sheath is greater than 1000 Megohms with 100VDC applied. At 312 °C and with dry external surfaces, the insulation resistance between each pin and the RTD sheath is greater than 1 Megohms at 100VDC applied.
Stability	RTD drift remains within 0.5 °C over a 40 year period exclusive of process-induced drift. Drift per year does not exceed 0.05 °C
Time Response	Sensor time response shall be less than 20.0 seconds for a 63.2% step change when installed in a Weed-designed thermowell and plunged from room temperature air into water at 180 °F (82 °C) flowing at 3ft/sec (1m/sec) traverse to the sensor.
Self Heating	Self Heating Error is less than 1.0 °C for 60 mW dissipation
Current	A continuous current of 7mA does not damage the sensor
Environmental/Seismic Qualification (Applicable Qualification/ Test reports are available upon request)	RTDs are qualified to IEEE-323 1974, 1983 and IEEE-344 1975, 1987 standards for design-qualified life of 40 years (300MRad gamma radiation). In addition, RTDs are vibration-tested to the following levels: Frequency 3-2500 Hz Cycling Speed 3-2500-3 Hz cycle in one hour Cycling Rate Logarithmic Vibration Level 0.762 mm (0.03 in) maximum peak-to-peak, subject to 3g maximum peak Test Duration 2 hours in each plane

Mechanical Specifications

Item	Specification
Element	Platinum
Sheath Material	Stainless steel
Insulation Material	MgO
Internal Leads	Constantan
End Connection	Hermetically Sealed 10SL size MS connector rated at 205°C
Mounting	Spring loaded with male bayonet for use with guide tube assembly
Weight	Nominal 0.5 to 0.75 lbs. without thermowell

Dimensional Drawing

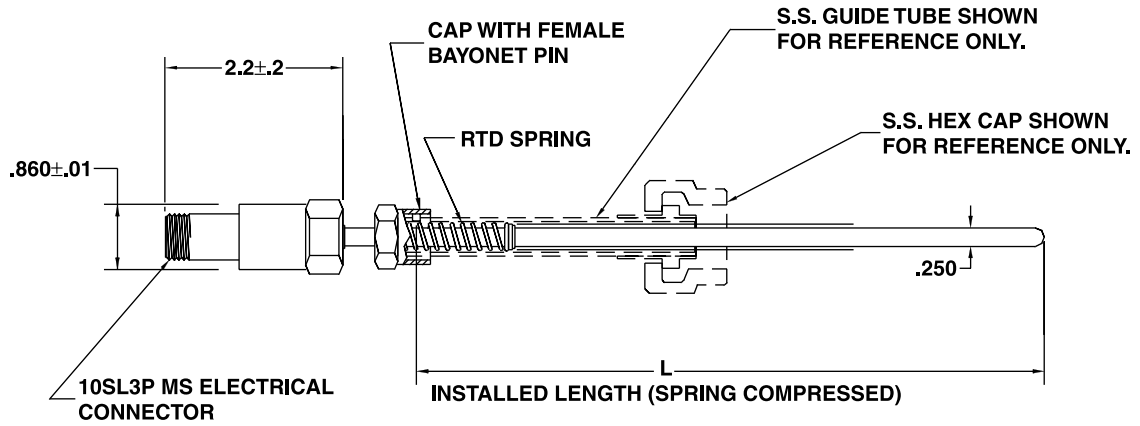

Qualified 3-pin connector

Typical mounting details for thermowell mount. Other arrangements are available.

Ordering Information

N9356	General Purpose Rigid RTD, spring loaded for use in thermowell, safety related	
S	Single Element (3 pin)	
X	Other, consult factory	
	R - zero temperature coefficient	
	1A	100 ohm Platinum, .003902 TCR 100 ohms at 0° C
	2A	200 ohm Platinum, .003902 TCR 200 ohms at 0° C
	1B	100 ohm Platinum, .00385 TCR 100 ohms at 0° C
	2B	200 ohm Platinum, .00385 TCR 200 ohms at 0° C
	1SP	100 ohm Platinum, Special TCR
	2SP	200 ohm Platinum, Special TCR
	Length	
	L	Length in inches

N9356 1A- L

Sample Model Number



Weed Instrument offers a wide variety of standard and customized nuclear-qualified RTD and thermocouple sensors, thermowells, pressure transmitters, temperature transmitters, and fiber optic modems. Please contact us for your specific needs.

Weed Instrument is a leading manufacturer of temperature and pressure measurement instrumentation and fiber optic data networking equipment for OEM, industrial, aerospace and nuclear applications. Our products include RTDs, thermocouples, temperature and pressure transmitters, and fiber optic modems. We are ISO 9001 registered and operate from a purpose built 50,000 square foot facility located on the outskirts of Austin, Texas.

We are recognized as an innovator in the instrumentation

market, having received multiple customer and industry awards during our 35 year history. Our products are used by virtually every global leader engaged in the Oil and Gas, Process, Power Generation, and Aerospace industries. Our strength lies in our ability to custom design products to customer specifications, as well as provide proven designs for "off the shelf" applications.

Weed Instrument is totally committed to providing quality products, timely deliveries and personalized service. Worldwide



sales support and flexible engineering, together with state-of-the-art manufacturing operations, allow us to consistently meet our customers sensing needs with reliable, practical and economical solutions.



Weed Instrument Company, Inc.
707 Jeffrey Way, P. O. Box 300
Round Rock, Texas 78680-0300
Phone: 512-434-2950, Fax: 512-434-2951
E-Mail: nuclear@weedinstrument.com
www.weedinstrument.com

